

ITEM: BALL END TURNBUCKLE

MATERIAL: TYPE 316 STAINLESS STEEL.

FITTING TYPE: ADJUSTABLE CABLE END TURNBUCKLE FOR ATTACHING & TENSIONING LINES.

SWAGE TYPE: MACHINE HEX SWAGE AT FACTORY (1/8" & 3/16" SIZES ALSO AVAILABLE IN CABLECRIMP HAND SWAGE STYLE FOR ATTACHING IN THE FIELD).

POST TYPE: METAL. WOOD POSSIBLE BUT NOT RECOMMENDED. (POSTS NOT INCLUDED).

FASTENING TO POST: ATTACH THROUGH END/TERMINATION POST HOLES USING A SCREW-ON BALL END.

FASTENING AT ANGLES: DRILL SLOTS OR ANGLED POST HOLES AND TURNBUCKLE WILL PIVOT ON BALL END.

CABLE TENSIONING: ADJUST BY TURNING TUBULAR TURNBUCKLE BODY.

HARDWARE PAIRINGS: USUALLY PAIRED WITH FIXED BALL END OR ANOTHER BALL END TURNBUCKLE. MAY ALSO USE ANY OTHER TENSION ADJUSTMENT FITTING OR FIXED END.

SUPPLIER: FEENEY ARCHITECTURAL PRODUCTS

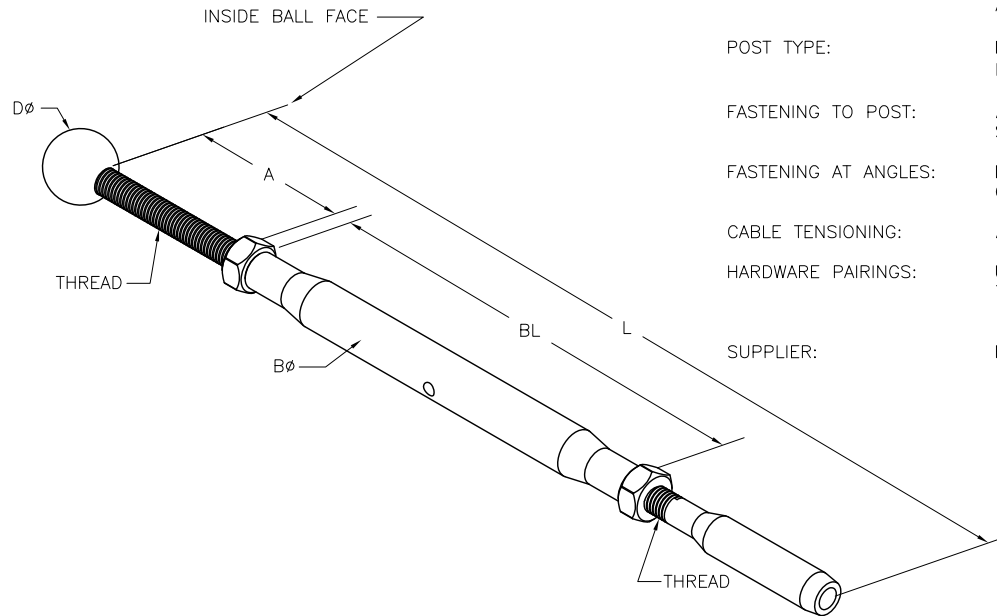

BALL END TURNBUCKLE, STAINLESS STEEL

PART#	SWAGE TYPE	CABLE SIZE	THREAD SIZE	BALL END DIA (Dø)	*SHAFT LENGTH CLOSED (OPEN) (A)	BODY LENGTH (BL)	BODY DIA (Bø)	LENGTH CLOSED (OPEN) (L)	**ATTACHMENT POST DRILL HOLE ø
3340	MACHINE	1/8"	1/4-28	5/8"	1-1/4"(2-7/8")	4-1/2"	7/16"	7-1/2" (10-1/2")	5/16"
3341	MACHINE	3/16"	1/4-28	5/8"	1-1/4"(2-7/8")	4-1/2"	7/16"	8" (11")	5/16"
3342	MACHINE	1/4"	5/16-24	5/8"	2-7/8"(4-7/8")	5-1/8"	1/2"	10-1/4" (14")	3/8"
3343	CABLECRIMP	1/8"	1/4-28	5/8"	1-1/4"(2-7/8")	4-1/2"	7/16"	8-1/4"(11-1/4")	5/16"
3344	CABLECRIMP	3/16"	1/4-28	5/8"	1-1/4"(2-7/8")	4-1/2"	7/16"	8-1/2"(11-1/2")	5/16"

*LONGER SHAFT LENGTHS ARE AVAILABLE AS A SPECIAL ORDER

** IF DESIRED THE BALL END CAN BE SLIGHTLY RECESSED INTO THE POST BY COUNTERBORING WITH A 9/16" DRILL

CableRail Reference Drawing:
BALL END TURNBUCKLE

THIS DRAWING IS THE PROPERTY OF FEENEY INC. ANY REPRODUCTION OF THIS DOCUMENT WITHOUT THE EXPRESSED WRITTEN CONSENT OF FEENEY INC. IS STRICTLY PROHIBITED.

DATE: 05/15/13
PAGE: 1 of 1
REV:
BY: DSY
CHK: BWA

feeney
makes it easy
2603 Union St., Oakland, CA 94607
P: 800-888-2418 F: 510-893-9484
www.feeneyinc.com